

15-CRS Series Heat Sealers

Automated Rotary Sealers for blisters, trays and carded packaging

Features

- Precision indexing drive
- Automatic blister & card feeders
- Automatic finished package eject
- Touch screen operator interface panel
- PLC controls
- Quick-change tools

The ZED Advantage

- Innovative technology
- Superior features
- Heavy duty design
- Excellent quality
- World-class performance
- Customized options
- Support and service



Description

ZED 15-CRS Series automated, rotary heat sealers are designed for high volume production requirements and are typically used for conventional carded blister packs. They feature automatic blister and card feeders as well as finished package ejectors. Locating pins on the aluminum turntable allow the use of quick-change seal tools – made of aluminum, phenolic or maple die board, depending on application requirements. State-of-the-art control system features a user-friendly touch screen operator interface to help speed up the learning and set-up process. The CRS-4 is a 4 station machine (with one open product loading station); the CRS-6 is a 6 station machine (with three open product loading stations); and the CRS-8 is an 8 station machine (with three to four open product loading stations). Optional quick-change blister and card hopper systems are also available to further increase productivity and versatility and help meet the needs of today's JIT and pack-to-order manufacturing environments.

Operation

ZED 15-CRS Series heat sealers

- place blisters automatically into seal tools,
- operators place products into the blisters as the tool indexes past their loading stations via an accurate, high-speed, cam-type drive system,
- automatically places cards on top of the seal tools,
- automatically seals blisters in the heat seal station, and
- automatically removes product from the heat seal tool by the finished package ejector.

Operator loading times may vary depending on the product, #-up tool matrix, etc. The adjustable timer control maximizes production by regulating dwell, heat, loading time, etc. Overall cycle speeds vary depending on the application – generally 8-20 per minute.

Specifications

| Model | 15-CRS-4 | 15-CRS-6 | 15-CRS-8 |
|-------------------------|----------------|--------------|----------------|
| Max. Sealing Area | 10" x 17" | 14" x 15" | 14" x 15" |
| Max. Part Height | 4" | 4" | 4" |
| Seal pressure @ 100 psi | 2800 lbs | 3600 lbs | 3600 lbs |
| Dimensions (LxWxH) | 7.5'x4.5'x5.5' | 5.5'x6'x5.5' | 7.5'x6.3'x5.5' |
| Speed (cycles/minute) | 8-20/min* | 8-20/min* | 8-20/min* |

* depending on application, #-up, blister & lid-stock material type, tooling, etc.

All listed specifications are approximate; final "as built" specifications depend on customer requirements. Other sizes and custom systems available on request.

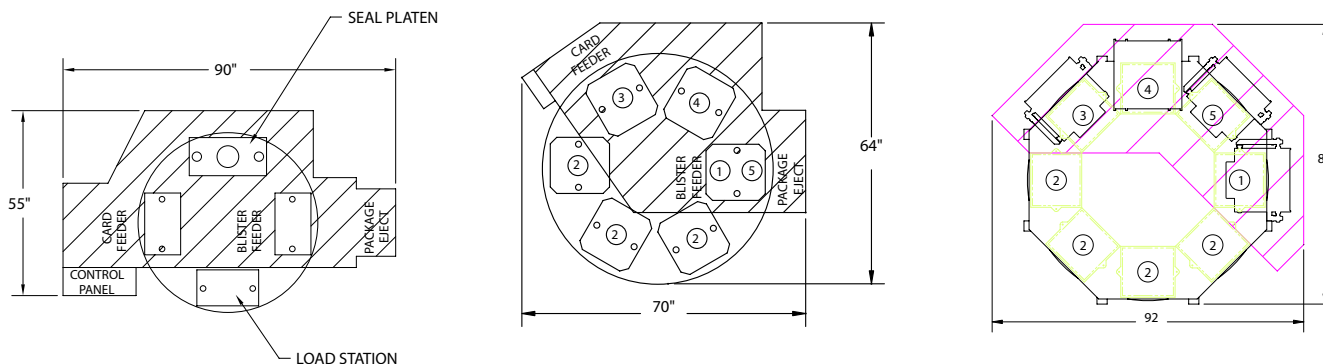

Customer Benefits

Start up assistance

Upon completion, the entire blister packaging system is prepared for production conditions, and customer personnel are completely trained at our facility. After approval, the system is shipped to customer's location. ZED technicians are available to provide on-site support.

Tooling

ZED Industries has complete state-of-the-art tooling facilities to provide laser-cut maple seal tools and CNC-machined aluminum seal tools, face plates and hoppers.

After-sale support

ZED Industries' fully qualified field service technicians provide unmatched field support for all of its packaging systems. In-house machine-, tooling-, and control systems engineers provide professional assistance via telephone or modem.

Marketing support

ZED Industries offers complete sales, marketing, engineering, and technical services to assist its customers at all levels of product development, machinery selection, materials and sampling to help bring products and packaging from concept to reality.

With over 50 years of experience, Zed Industries is the leading manufacturer of thermoforming and plastic packaging equipment including heat sealers for carded blister packs and clamshells, skin packers, die cutters, form/fill/seal equipment, thermoformers and custom engineered packaging systems.



3580 Lightner Road
Vandalia, OH 45377

T: 937-667-8407
F: 937-667-3340

www.zedindustries.com
info@zedindustries.com